

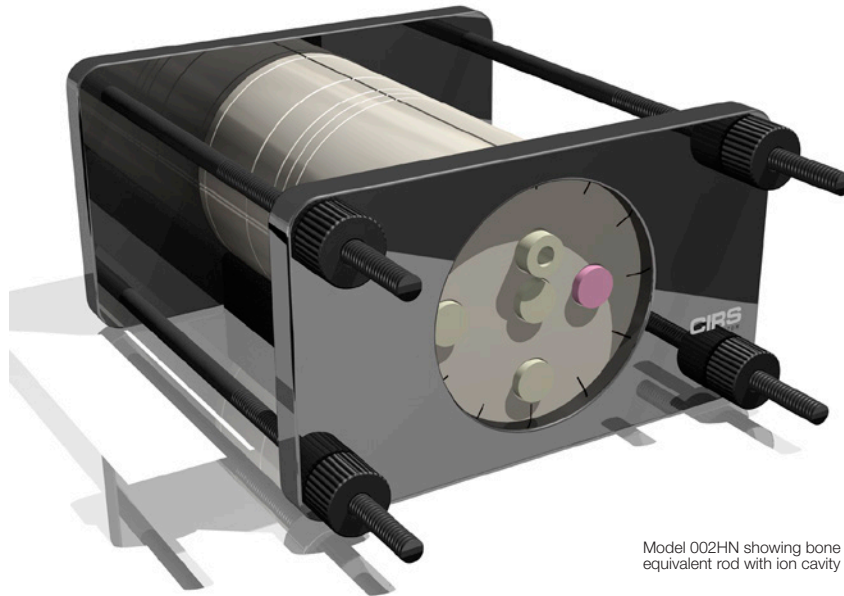

IMRT Head and Neck Phantom

Model 002HN



Model 002HN showing bone equivalent rod with ion cavity

COMPLETE QA FROM CT IMAGING TO DOSE VERIFICATION

The CIRS Model 002HN IMRT phantom is designed to address the complex issues surrounding commissioning and comparison of treatment planning systems and verification of individual patient plans and delivery.

The CIRS 002HN phantom properly represents human head and neck anatomy in shape, proportion and structure as well as density. This enables thorough analysis of both the treatment planning and delivery systems. The phantom is constructed of proprietary tissue equivalent epoxy materials. Linear attenuations of the simulated tissues are within 1% of actual attenuation for bone and water from 50 keV to 15 MeV.

The phantom is circular in shape, approximates the size of an average patient. Tissue equivalent interchangeable rod inserts for ionization chambers allow for point dose measurements in multiple planes in the phantom, film calibration and isodose normalization.* The phantom also supports film dosimetry with not only standard radiographic films but also GafChromic® media¹. Additional inserts are available to support a variety of other detectors including TLD's, MOSFET, and diodes.

The Model 002HN accommodates one Ready Pack™ containing 10" x 12" films in transverse orientation, two

radiochromic or radiographic 10 x 10 cm films in transverse orientation and a stack of thirteen radiochromic films pre-cut to 63.5 x 63.5 mm in three different orientations.

The Model 002HN has an optional four Electron Density reference plugs which can be interchanged in five separate locations within the phantom. The surface of the phantom is etched with grooves to ensure proper orientation of the CT slices and accurate film to plan registration. An optional cranial bone ring is also available.

Features

- Verify heterogeneity corrections
- Correlate CTU to electron density
- Check dose distributions in sensitive areas
- Check depth doses and absolute dose
- 2D and 3D isodoses
- Calibrate film with ion chamber*
- Verify individual patient treatment plans

¹ The CIRS line of IMRT phantoms is compatible with the RIT 113 software for film to plan analysis. GafChromic® is a registered trademark of International Specialty Products, Wayne, NJ.

IMRT VERIFICATION SYSTEM

CIRS IMRT phantoms are manufactured from tissue equivalent materials that mimic within 1% from 50 keV to 15 MeV for accurate simulation from CT planning to treatment delivery. The interchangeable rod design allows the phantom to accommodate a multitude of dose measurement devices such as ion chambers, TLD, diodes and MOSFET's in the same location within the phantom. * Phantom cross sections accommodate GafChromic® or standard ready-pack films.

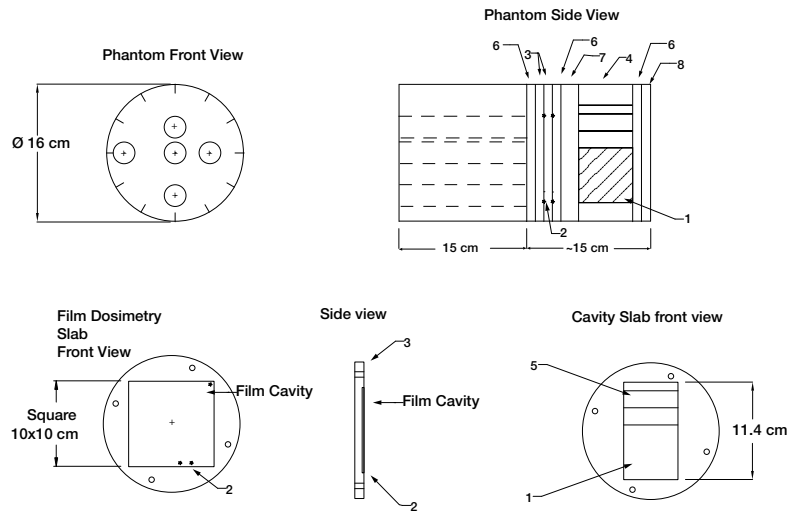

- 1 - Film Stack 002FC or Gel Cassette 002GC
- 2 - Fiducial Markers
- 3 - 1 cm Film Dosimetry Slabs
- 4 - Cavity Slab

- 5 - 1 cm and 2 cm spacers for Film Stack positioning
- 6 - 1 cm spacer slabs
- 7 - 2 cm spacer slabs
- 8 - 1.6 cm end slabs

SPECIFICATIONS

OVERALL DIMENSIONS:	43.2 cm x 33 cm x 20.3 cm (17" x 13" x 8")
WEIGHT:	10.5 kg (28 lb)
MATERIALS:	Phantom Body: Tissue Equivalent Epoxy Materials Inserts: CIRS Tissue Equivalent Materials (epoxy resin based)

INSERT OPTIONS

*Customers are encouraged to complete their order with the purchase of at least one (1) of each insert option listed below. Refer to separate CIRS cavity and plug code list for available chamber cavities.

PART NO.	DESCRIPTION
002RW-CVXX-XX	Water equivalent rod insert with ion chamber cavity
002RB-CVXX-XX	Bone equivalent rod insert with ion chamber cavity

MODEL 002HN INCLUDES

QTY	PART NO.	DESCRIPTION
1		Water equivalent homogeneous section drilled to accommodate rod inserts (15 cm)
2		Film slabs, 1 cm, film cavity 10 cm x 10 cm with a set of CT to film fiducial markers
1		CT to film fiducial markers in film slabs
1		Cavity slab, 6.34 cm, to accommodate film stack or gel cassette
1	002FC	Film Stack for small volume 3D image reconstruction
1		Spacer slabs, 2 cm
2	002SS-HN	Spacer slab, 1 cm
1	002SS-HN	End slab, 1 cm
1		End slab, ~1.6 cm
5	002RW-S	Water equivalent solid rod inserts
1	002RB-S	Bone equivalent solid rod insert
1		Alignment base
1		Holding device

ADDITIONAL OPTIONS

PART NO.	DESCRIPTION
002GC	Gel dosimetry cassette
002SPH	Water equivalent rods for TLD's (set of 5 rods length 5cm)
002ED	Electron density reference plugs, set of 4 (lung, bone, muscle, adipose)
002CTF	Set of CT to film fiducial markers for additional interfaces
9503	Case for Model 002HN

References:

Gershkevitch, Eduard, et al., Dosimetric Verification of Radiotherapy Treatment Planning Systems: Results of IAEA Pilot Study. 2008 Elsevier Ireland Ltd., Radiotherapy and Oncology 89 (2009) 338-346, pgs. 338-346, March 2009.

Zhao, Y. et al., Monte Carlo evaluation of a treatment planning system for helical tomotherapy in an anthropomorphic heterogeneous phantom and for clinical treatment plans. Med. Phys., vol. 35 (12), pgs. 5366-5374, December 2008.

Luo, W., et al., Analysis of image quality for real-time target tracking using simultaneous kV-MV imaging. Med. Phys., vol. 35 (12), pgs. 5501-5509, December 2008.

Brunckhorst E., et al., Commissioning of Radiotherapy Treatment Planning Systems: Testing for Typical External Beam Treatment Techniques. IAEA, International Atomic Energy Agency, IAEA-TECDOC-1583, pgs. 1-67, January 2008.

Altman, M., et al., A Novel Phantom for use in 3-dimensional In Vitro Cell Experiments. Med. Phys., vol. 33 (6), pgs. 2058-2059, Poster # SU-FF-T-40, June 2006.

